

1. CRI does not recommend roller style trailers. Roller trailers will void your hull warranty.
2. All NX Series boats have a 5 degree deadrise and a long planing pad. Do not use keel rollers. Keel rollers can create dimples in the planing pad over time.
3. Drawings do not show centering bunks. CRI highly recommends centering bunks running from approximately the axle location to the forward cross member. Centering bunks should support either side of the planing pad in the back and the gap should taper together forward to about 8 inches apart at the front cross member.

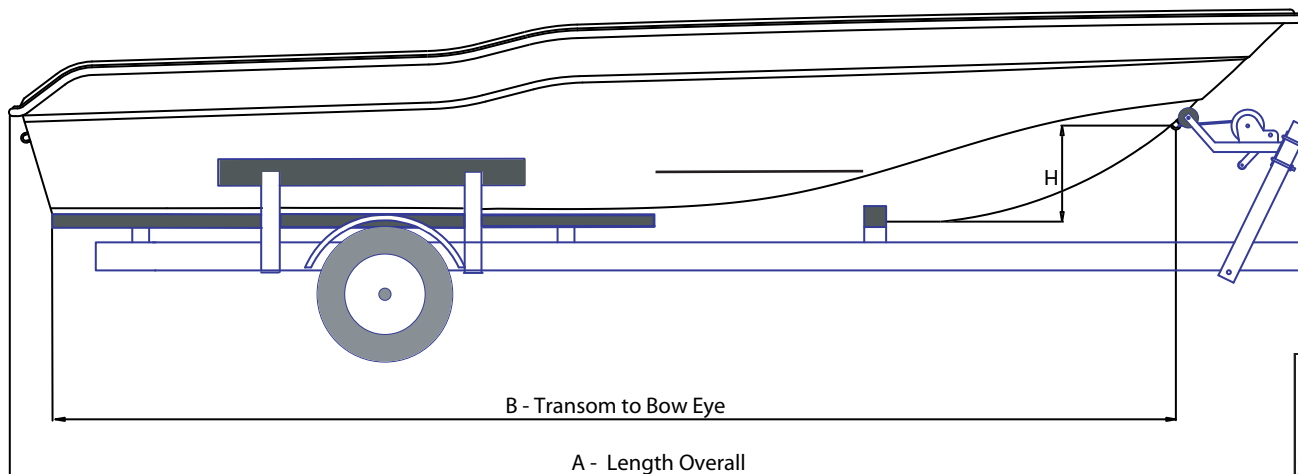

Locating 4 foot long carpeted side guides over the wheel fenders is recommended for easy loading.



Recommended Bow Stop and Side Rollers

Model	A	B	C	D	E	F	G	H	W1	W2
NX17	17'-2"	14'-6"	89"	66"	21"	1-1/4"	2-3/8"	20"	1350	2050
NX19	18'-10"	16'-2"	89"	66"	21"	1-1/4"	2-3/8"	20"	1525	2225
NX21	21'-1"	17'-10"	97"	74"	22-1/2"	1-1/2"	3"	22.5"	1850	2790
NX23	23'-1"	19'-10"	99"	74"	22-1/2"	1-1/2"	3"	22.5"	2225	3440
NX25	25'-1"	21'-10"	102"	74"	22-1/2"	1-1/2"	3"	22.5"	2600	4005

A = Length Overall
 B = Length Transom to Bow Eye
 C = Beam Overall
 D = Chine to Chine Beam

E = Keel to Inside Bunk Edge
 F = Deadrise from Keel to Inside Bunk Edge
 G = Deadrise from Keel to Chine
 H = Height of Bow Eye over Keel

W1 = Weight of Hull Only
 W2 = Weight of Hull, Max Engine,
 Full Fuel, Batteries, Gear