SeaLand® GRAVITY DISCHARGE TOILET OWNER'S MANUAL

SeaLand® 711-M28 Toilet



WARNING

This manual must be read and understood before adjustment, maintenance, or service is performed. Modification of this product can result in property damage.

SeaLand®
by Dometic GROUP

TABLE OF CONTENTS

Specifications	2
Recommendations	2
Installation Instructions	2 - 4
Operating Instructions	4
Maintenance	4 - 5
Preparing for Summer Use	5
Model Identification	5
Spare Parts	5
Customer Service	5
Troubleshooting Guide	6
Limited Warranty	8

SPECIFICATIONS

Product Name: 711-M28 SeaLand Marine Toilet

Shipping Information:

Carton Sizes:

Toilet	21" x 18-1/2" x 13-1/2" (533mm x 470mm x 343mm)
Tank	19-1/4" x 17-1/2" x 11-1/2" (489mm x 445mm x 292mm)
Weight	Approx. 49 lbs. (22Kg)

System:

Average water consumption per flush	1 Qt. (.95L)
Minimum water consumption per flush	1 Pt. (.47L)
Holding tank capacity	9.5 Gal. (36L)
Fresh water supply pressure	5-80 PSI
Water inlet size	1/2" NPT
Holding tank discharge fitting	1-1/2" NPT
Vent fitting	5/8" Barb
Unit weight	41 Lbs. (19Kg)

Dimensions:

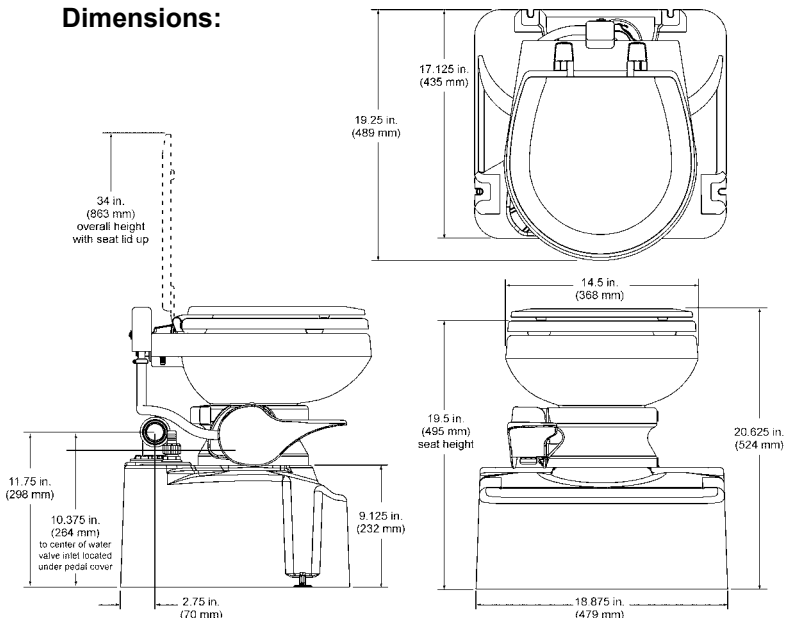

RECOMMENDATIONS

1. Read the "Operating Instructions" section of the manual carefully.
2. Make sure all guests understand the operation of the SeaLand toilet.
3. Carry a few spare parts for the maintenance purposes. Dometic has developed several repair kits that will save you both time and expense should a problem occur. See "Customer Service" section of this manual.
4. Use only SeaLand brand® Tissue and SeaLand® brand Holding Tank Deodorants to maintain a trouble-free system.
5. Do not use chlorine or caustic chemicals, such as laundry bleach or drain opening types, in the system. These products damage the seals in toilets.
6. Do not flush foreign objects through the toilet.
7. Do not allow small problems to go unsolved. As soon as a problem is detected, correct it.

INSTALLATION INSTRUCTIONS

Tank:

1. Select position in bathroom where unit can operate properly. Allow room for using the flush lever and clearance for raising the seat and lid.
2. Position the tank 3/4" (19mm) away from the wall. Mark four holes at mounts on tank base. After holes are marked, remove tank, and drill pilot holes. Slide tank back into position. Secure the tank with four #14 x 2" long pan head screws and washers on all tank mounts.

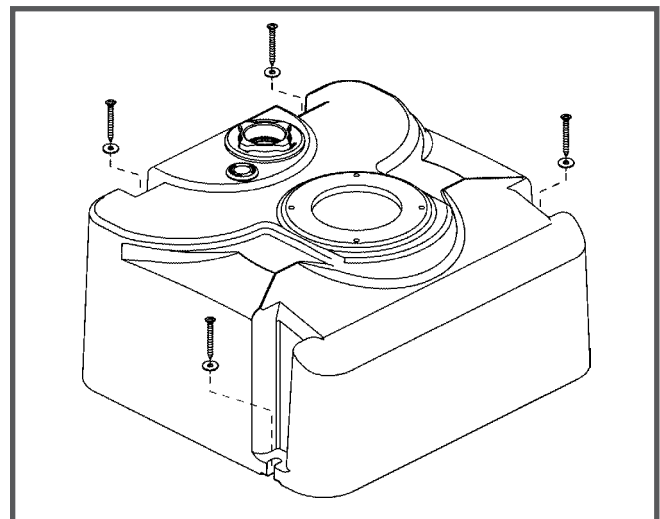

3. Run 5/8" (16mm) I.D. hose to vent fitting and secure with hose clamps.

Install thru-hull vent fitting:

- (not supplied with unit – SeaLand part number 307236368)
4. Drill hole through the hull, well above water line and directly above SeaLand toilet. Hole location is determined by routing and length of hose.

INSTALLATION INSTRUCTIONS (cont'd)

5. Apply waterproof caulk around underside of thru-hull vent fitting.
6. Install thru-hull vent fitting and secure snugly with nut. Wipe off excess caulk with damp cloth.
7. Attach remaining end of vent hose to thru-hull fitting with hose clamp.

Dockside Discharge Fitting: (not supplied by SeaLand)

8. Drill hole in deck directly above SeaLand toilet. Hole location is determined by routing space and length of hose.
9. Screw 1-1/2" FPT x 1-1/2" hose barb into bottom of deck fitting.

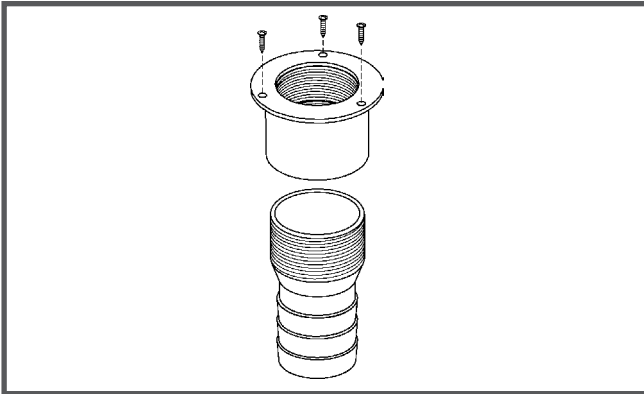

10. Apply waterproof caulk around deck hole and install deck fitting into 2-1/4" (57mm) hole with screws. Wipe off excess caulk with a damp cloth.
11. Install 1-1/2" MPT x HUB adapter into discharge fitting on holding tank. If necessary, PVC cement elbow and hose adapter or hose adapter only into 1-1/2" (38mm) adapter. Secure 1-1/2" (38mm) hose to adapter with hose clamp.



12. Route hose from tank to deck fitting and secure with hose clamp.

Note: The holding tank on the 711-M28 is designed to withstand discharge by a properly operating discharge pump.

Toilet Installation:

13. Push button on back of flush pedal, then pull flush pedal cover away from pedal to expose water valve. Remove plastic pedestal cover from toilet base.



14. Install the (4) 1/4-20 x 1-3/4" long studs in inserts on the tank top.

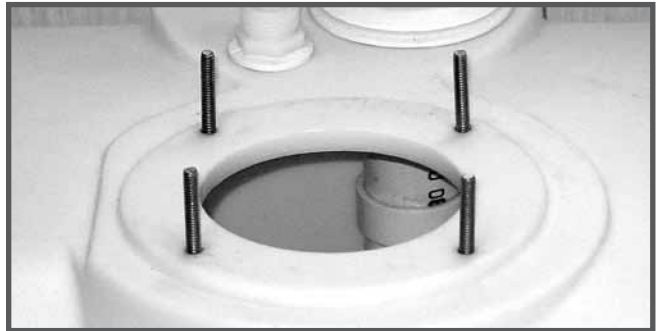

15. Place floor flange seal on studs, aligning the studs with bumps on seat. Note: "THIS SIDE UP" should face upwards.



16. Place toilet on studs and secure with four washers and four nuts.



INSTALLATION INSTRUCTIONS (cont'd)

Water line:

17. Locate water valve at rear of flush lever.
18. Attach water supply pipe or hose from water system to inlet fitting on back of water valve.

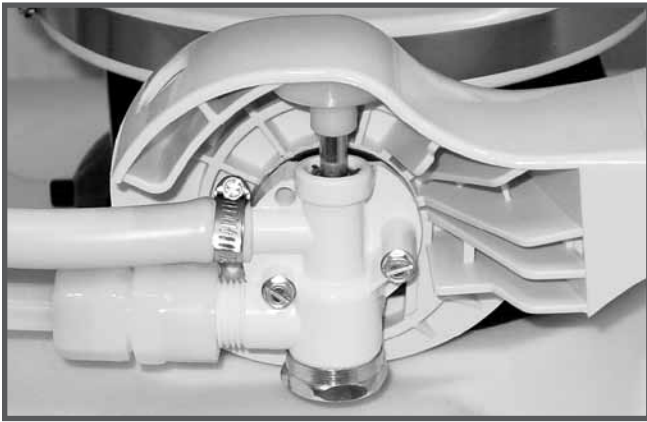

Pedestal cover:

19. Slide back side of pedestal cover around rear of toilet base and snap in groove. Close front half of pedestal cover and snap in groove.



Flush pedal cover:

20. Put flush pedal cover back in place.

OPERATING INSTRUCTIONS

To properly use the SeaLand toilet, follow these simple instructions:

1. A good biodegradable tissue such as SeaLand® brand is recommended.
2. To add water to the toilet before using, lift or raise the flush pedal.
3. To flush toilet, push pedal all the way down until sewage leaves the toilet bowl. Water flow pressures vary at different locations and therefore, holding the flush lever down 4-8 seconds may be required. We recommend 2-4 GPM (8-15 Lpm) for proper rim and bowl wash.
4. Release flush pedal by allowing it to snap back, which permits positive sealing around the flush ball.
5. A small amount of water should remain in the bowl.

Note: Holding the flush pedal down longer than necessary results in excessive water usage.

CAUTION: Do not dispose of sanitary napkins or other non-dissolving items in the toilet.

MAINTENANCE

CLEANING

The SeaLand toilet should be cleaned regularly for maximum sanitation and operational efficiency.

Clean the toilet bowl with a mild bathroom cleaner, such as SeaLand® Toilet Bowl Cleaner. Do not use chlorine or alcohol-based caustic chemicals such as drain opening types, as they will damage the seals.

If an odor is apparent from the toilet:

1. Clean out system by flushing several gallons of fresh water through with one cup of liquid laundry soap.
2. Add odor control deodorant in amount specified for your holding tank capacity after cleaning and every few days during use.

WINTERIZING

At the end of each season, the SeaLand toilet should be winterized for storage by either draining or using potable, water-safe antifreeze in the system.

To drain:

1. Thoroughly flush system with fresh water.
2. Empty holding tank.
3. Shut off water supply to toilet. Remove inlet waterline.
4. Press flush lever until all water is drained from toilet.

MAINTENANCE (cont'd)

To use antifreeze:

1. Thoroughly flush system with fresh water.
2. Empty holding tank.
3. Drain potable water tank.
4. Add freshwater antifreeze and water mixture through toilet and into the waste holding tank. Each installation is different, so amounts may vary. User discretion is required to assure adequate protection.
5. Empty holding tank.

Note: Use nontoxic antifreeze designated for potable water systems (see boat owner's manual).

CAUTION: Never use automotive-type antifreeze in freshwater systems.

PREPARING FOR SUMMER USE

To prepare the SeaLand toilet for summer use, turn on water supply and check system for leaks. Flush toilet, check for leaks and repair as necessary. Your SeaLand toilet is now ready for use.

MODEL IDENTIFICATION

The model identification label is located on the base of the toilet under the pedestal cover (see back page for illustration).

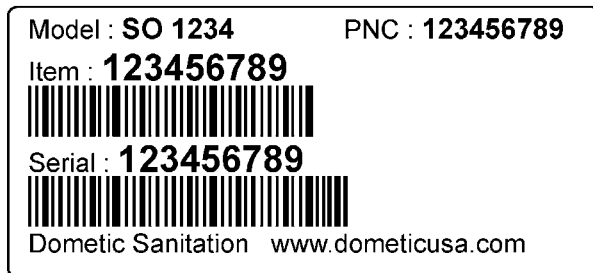

SPARE PARTS

Your SeaLand 711-M28 toilet is designed for years of dependable trouble free service. However, during the life of the product certain parts may require replacement. The following is a list of parts kits which may be required for maintenance purposes.

Part Number	Description
385310681	Ball, Shaft & Cartridge Kit
385311462	Seal Kit
385314349	Water Valve Kit
385316906	Vacuum Breaker Kit

CUSTOMER SERVICE

Dometic has a strong, worldwide network to assist in servicing and maintaining your SeaLand toilet if parts or service are required. Before calling, please have the following information available. Your cooperation in having this information ready is appreciated and allows our Customer Service Department to better meet your needs. When you call, we will direct you to the nearest parts distributor.

1. Toilet Model Number
2. Serial Number
3. Part Number, Description and Quantity (See Parts List.)

When you have gathered all the required information, call us at one of the following telephone numbers from 8:00 a.m. to 5:00 p.m. (Eastern Time) Monday through Friday, or email us.

Telephone: 1-800-321-9886 USA and Canada
330-439-5550 International

Fax: 330-496-3097 USA and Canada
330-439-5567 International

Email: sealand@dometicus.com

TROUBLESHOOTING GUIDE

Problem	Possible Cause	Service Instructions
1. Water will not stay in bowl.	<ul style="list-style-type: none"> a. Loose clamp. b. Improper seal around flush ball due to dirt or debris on underside of flush ball seal. c. Worn or damaged seal. d. Worn or damaged flush ball. 	<ul style="list-style-type: none"> a. Tighten clamp ring adjusting nut. b. Inspect flush ball and underside of seal for foreign objects. Clean if necessary. c. Replace seal. d. Replace flush ball.
2. Plastic flush ball will not close completely.	<ul style="list-style-type: none"> a. Clamp ring is overtightened, causing too much tension on seal and flush ball. b. Weak or defective spring cartridge. 	<ul style="list-style-type: none"> a. Loosen clamp ring. b. Check spring tension by letting up on flush lever suddenly. If lever does not snap back, replace spring cartridge.
3. Water does not shut off in toilet (toilet overflows).	<ul style="list-style-type: none"> a. Dirt lodged in water valve seal. b. Cam strap is bent down, holding water valve open. c. Worn or defective water valve. d. Worn or defective spring cartridge. 	<ul style="list-style-type: none"> a. Disassemble and clean water valve. b. Bend front of cam strap up about 1/16" (1.6mm). c. Replace water valve assembly. d. Replace spring cartridge.
4. Water does not enter toilet bowl properly.	<ul style="list-style-type: none"> a. Low water pressure. b. Water valve clogged. 	<ul style="list-style-type: none"> a. Check incoming water pressure. b. Remove and clean filter screen located on inlet of water valve.
5. Water leaking from water valve.	<ul style="list-style-type: none"> a. Loose connection. b. Worn or defective water valve. c. Water line connection not seated properly. d. Stripped threads. e. Seal worn or missing. f. Valve body cracked. 	<ul style="list-style-type: none"> a. Tighten bottom cap, inlet fitting and outlet hose clamp. b. Replace water valve. c. Insure that threads are not cross-threaded and tighten. d. Replace water valve. e. Replace water valve. f. Replace water valve.
6. Water leaking from rear of toilet bowl.	<ul style="list-style-type: none"> a. Loose hose connection. b. Loose vacuum breaker. c. Worn or defective vacuum breaker. d. Cracked or defective toilet bowl. 	<ul style="list-style-type: none"> a. Tighten hose connections. b. Tighten vacuum breaker-to-bowl connection. c. Replace vacuum breaker assembly. d. Replace toilet bowl.

This page is intentionally left blank.



Limited Warranty

THE SELLER NAMED BELOW MAKES THE FOLLOWING WARRANTY WITH RESPECT TO
SEALAND GRAVITY-FLUSH TOILET MODEL 711-M28 ONLY

1. TWO-YEAR LIMITED WARRANTY

- 1A. This Limited Warranty will be in effect for two years from the date of purchase.
- 1B. This Limited Warranty is made only to the First Purchaser (hereinafter called the "Original Purchaser") who acquired the product for Original Purchaser's personal, family, or household-type use. The Original Purchaser should retain a copy of the sales receipt or invoice as evidence of the date of purchase because proof of purchase is required to obtain warranty service.
- 1C. If this product is placed in commercial or business use, it will be warranted, to the Original Purchaser only, to be free of defects in material and workmanship for a period of 90 days from the date of purchase.
- 1D. This warranty covers all parts of the Dometic toilet which is warranted to be free of defects in material and workmanship under normal use. This warranty does not cover conditions unrelated to the material and workmanship of the product. Such unrelated conditions include, but are not limited to, (a) faulty installation and any damage resulting from such; (b) the need for normal maintenance and any damage resulting from failure to provide such maintenance; (c) failure to follow Seller's instructions for use of this product, including failure which may result from not following winterization procedures; (d) any accident that results in damage to this product; (e) scratching or staining of any ceramic or plastic component; and (f) acts of God, or misuse of any part of this product and any alteration by anyone other than the Seller.
- 1E. For Original Purchaser (ONLY) to obtain the benefits of this Warranty during the 2-year period (for personal use) or 90-day period (for commercial use), the following shall apply:
- (a) Original Purchaser shall contact the local dealer from whom the product was purchased; or contact the Seller Customer Service Department at 1-800-321-9886 (8 a.m.-5 p.m. ET, USA) and provide the local dealer or Seller Customer Service Department with sales receipt or invoice, product model and serial number from product. The product model identification label is located on the toilet base under the pedestal cover (see illustration).
 - (b) If product, while still under warranty, is returned to local dealer where purchased, the local dealer will repair, replace or refund the product per this Warranty and as authorized by the Seller. Seller will provide necessary replacement parts or product free of charge to Original Purchaser, including freight on such replacement parts or product, and Seller will pay direct labor charges for such repair or replacement.
 - (c) Under no circumstances will Seller pay or be liable for any of Original Purchaser's or dealer's travel charges or other expenses associated with bringing the product or recreation vehicle to the dealer for repair, for providing dealer with access to the product or vehicle, or for downtime of the product or vehicle.
 - (d) Original Purchaser may be required to return defective product or parts when requested by Seller; in such event, Seller will pay related freight costs.

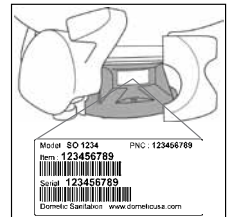

Location of product ID label

2. THE SELLER DOES NOT AUTHORIZE ANY PERSON OR COMPANY TO CREATE OR EXTEND ANY WARRANTY OBLIGATIONS OR LIABILITY ON ITS BEHALF.

3. REPAIR OR REPLACEMENT OF, OR REFUND FOR, DEFECTIVE PRODUCT, AT SELLER'S OPTION, SHALL BE THE ORIGINAL PURCHASER'S SOLE REMEDY UNDER THIS LIMITED WARRANTY. IN NO EVENT SHALL SELLER BE LIABLE FOR PURCHASER'S INCIDENTAL OR CONSEQUENTIAL DAMAGES. SOME STATES DO NOT ALLOW THE EXCLUSION OR LIMITATION OF INCIDENTAL OR CONSEQUENTIAL DAMAGES, SO THE ABOVE LIMITATION OR EXCLUSION MAY NOT APPLY TO YOU.

4. SELLER DISCLAIMS ALL OTHER WARRANTIES WITH RESPECT TO THE PRODUCT, WHETHER EXPRESS OR IMPLIED, AND SPECIFICALLY DISCLAIMS THE IMPLIED WARRANTIES OF MERCHANTABILITY AND FITNESS FOR A PARTICULAR PURPOSE. SOME STATES DO NOT ALLOW LIMITATIONS ON IMPLIED WARRANTIES OR HOW LONG AN IMPLIED WARRANTY LASTS, SO THE ABOVE LIMITATION MAY NOT APPLY TO YOU.

5. THIS WARRANTY GIVES YOU SPECIFIC LEGAL RIGHTS, AND YOU MAY ALSO HAVE OTHER RIGHTS WHICH VARY FROM STATE TO STATE.

SELLER:
Dometic Corporation - Sanitation Div.
13128 SR 226
Big Prairie, Ohio 44611 USA
330-439-5550

Dometic Group is a customer-driven, world-leading provider of leisure products for the RV, automotive, truck and marine markets. We supply the industry and aftermarket with a complete range of air conditioners, refrigerators, awnings, cookers, sanitation systems, lighting, mobile power equipment, comfort and safety solutions, windows, doors and other equipment that make life more comfortable away from home.

Dometic Group supplies a wide range of workshop equipment for service and maintenance of built-in air conditioners. Dometic Group also provides specially designed refrigerators for hotel rooms, offices, wine storage and transport and storage of medical products.

Our products are sold in almost 100 countries and are produced mainly in wholly-owned production facilities around the world.



DOMETIC CORPORATION
SANITATION DIVISION
13128 SR 226 | PO BOX 38
BIG PRAIRIE, OHIO 44611 USA
www.DometicSanitation.com
sealand@dometicus.com